

FPGA Implementation of Multiple Controllers for a Magnetic Suspension System

Project Proposal

By: Chris Olivera

Project Advisor: Dr. Winfred Anakwa and Dr. Yufeng Lu

Date: February 18, 2014

Abstract

System modeling and dynamics of the magnetic suspension system are interesting and challenging due to the nonlinear nature of the system. A nonlinear plant model has been studied and linearized. Different controllers have been designed and implemented on various hardware platforms including xPC Target Box and Motorola ColdFire microcontroller using Simulink and real-time workshop. Considering the very costly price ranges of such hardware, this project's original objective was to implement multiple controllers for the magnetic suspension system using a low-cost Field Programmable Gate Array board. However, only one previously designed controller was implemented. FPGA has advantages in design flexibility and functional enhancement. A system has been designed and implemented to demonstrate the controller for the magnetic suspension system. The system includes Spartan3E FPGA, digital-to-analog (D/A) converter, analog-to-digital (A/D) converter, and conditioning circuitry. The previous controller has been simulated using Xilinx system generator, a design tool for FPGA fixed-point implementation. In addition, the controller has been programmed in VHDL for FPGA implementation. This study shows that the Xilinx system generator is an efficient design tool for adjusting finite word-length, and FPGA is a viable platform for controller implementation.

Introduction

System modeling and dynamics of the magnetic suspension system are interesting and challenging due to the nonlinear nature of the system. A linear plant model has been studied and different controllers have been designed and implemented on various hardware platforms including xPC target box and Motorola ColdFire microcontroller using Simulink and Real-time workshop [1, 2]. Field Programmable Gate Array (FPGA) has been widely used in embedded applications. It has advantages in design flexibility and functional enhancement. In this project, an FPGA is used to implement a controller for a magnetic suspension system. The motivation for this project is mainly to reduce costs. In addition, this project proves that an FPGA board can be used for controller implementation. This has not been done before in the ECE Department of Bradley University. Figure 1 shows the Spartan3E FPGA Board used in this project.



Figure 1 - Spartan3E FPGA Board

Background

Magnetic suspension systems are progressively used in industrial rotating machinery applications. They offer a number of practical advantages such as capacity for linear displacement, can operate at extreme temperatures with a longer lifespan, high rotational speeds, and low energy consumption. The problem of lubrication is eliminated by the absence of mechanical contacts that are present. The magnetic suspension system uses an electromagnetic force to suspend a hollow metal ball [3].

A schematic diagram of the magnetic suspension system is shown in Figure 2.

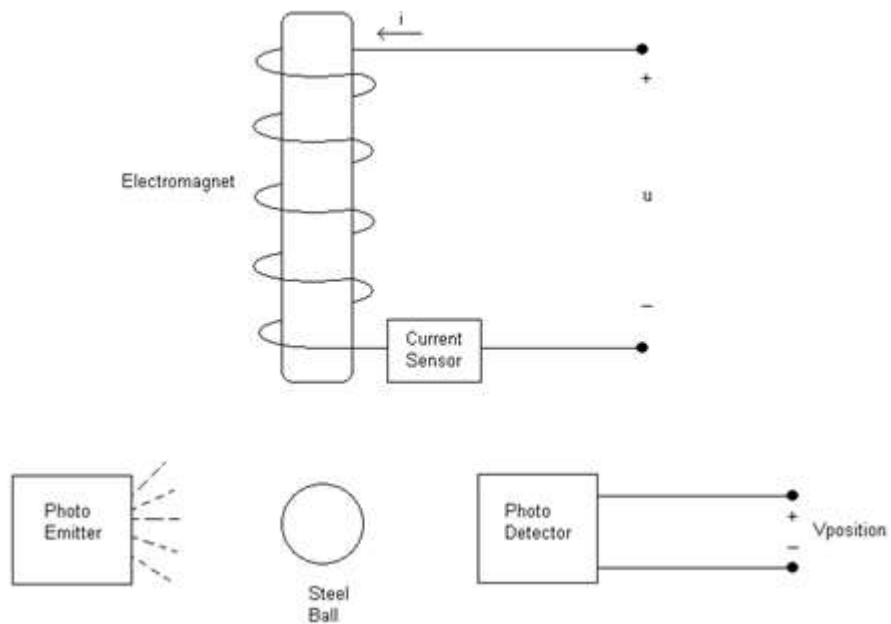

Figure 2 - Schematic Diagram of a Magnetic Suspension System [1]

Many controller design methods may be used to design controllers to satisfy performance goals. The controller design method used in this case relies heavily on a detailed mathematical model of the plant. The general nonlinear mathematical model of the magnetic suspension system is

$$\dot{x}_1 = x_2 \quad (1)$$

$$\dot{x}_2 = g - \frac{k}{m} \left(\frac{x_3}{x_1} \right)^2 \quad (2)$$

$$\dot{x}_3 = -\frac{R}{L} x_3 + \frac{2k}{L} \left(\frac{x_2 x_3}{x_1^2} \right) + \frac{u}{L} \quad (3)$$

where R is the resistance of the coil, L is the inductance of the coil, m is the mass of the steel ball, k is the force constant, x_1 is the distance of the steel ball from the electromagnet, x_2 is the velocity of the steel ball and x_3 is the coil current [1]. The model given in Eq. (3) assumes that the coil current is generated by the control voltage u directly.

Figure 3 shows the Feedback Incorporated Magnetic Suspension System.



Figure 3 - Magnetic Suspension System

However, the schematic diagram of the magnetic suspension system developed by Feedback Incorporated, shown in Figure 4, uses an active coil driver circuit to generate the coil current, and the force constant k cannot be easily measured. For these reasons a linear mathematical model was obtained experimentally in a previous student project.

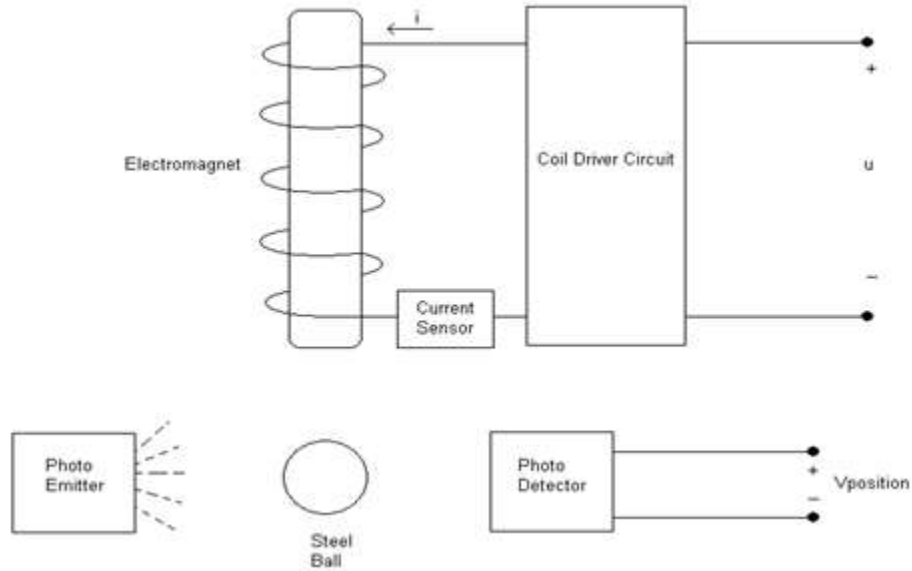

Figure 4 - A Schematic Diagram of Feedback Incorporated Model 33-210 Magnetic Suspension System [1]

The method of choice for this project is the Internal Model Principle, which was developed by B.A. Francis and W.M. Wonham [4]. The theory behind the Internal Model Principle is that the controller should include the model of the disturbance so that it can be rejected.

The Internal Model Principle is a mathematical approach to controller design. The actual model that is created using this method is a polynomial consisting of the least common factors of the unstable denominator roots of both the reference input signal and the disturbance to be rejected. In this project the reference input was considered to be a step function. The continuous transfer function was converted to a discrete transfer function using a “zero-order hold” method in MATLAB with a sample time of 1ms. A table of discrete transfer function denominators and their associated models appear in Table 1.

Functions	Continuous	Discrete	Model
Step	$\frac{1}{s}$	$z - 1$	$z - 1$
Ramp	$\frac{1}{s^2}$	$z^2 - 2z + 1$	$z^2 - 2z + 1$
Sinusoidal	$\frac{a}{s^2 + a^2}$	$z^2 - 2z \cos(.001 * a) + 1$	$(z^2 - 2z \cos(.001 * a) + 1)(z - 1)$

Table 1 - Table of Models for Specific Disturbance Classes

Once the model has been created, the model is inserted into the denominator of the controller to be designed. Figure 5 shows the proper placement of the model, $P(z)$, in the denominator of the controller $B(z)/A(z)$.

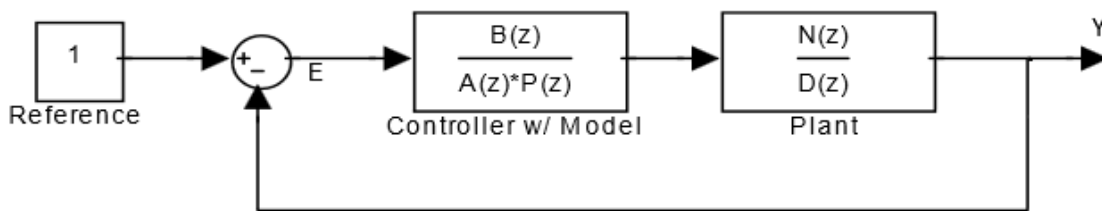

Figure 5 - Block Diagram Showing Location of Model and Controller Polynomials

The denominator of the closed loop system in Figure 5 is found to be $D(z)P(z)A(z)+B(z)N(z)$. In this equation, N , D and P are known polynomials from the plant and the model. This leaves $A(z)$ and $B(z)$ to be found.

Solving a Diophantine equation of the form

$$D(z)P(z)A(z)+B(z)N(z) = F(z) \quad (4)$$

both $A(z)$ and $B(z)$ can be determined assuming $D(z)$ and $N(z)$ of the plant are co-prime. The polynomial $F(z)$ is a performance polynomial with roots at desired locations in the unit circle in the z -plane. These roots are placed at locations to achieve low percent overshoot, fast settling time and a minimal control signal.

The order of $F(z)$ is dependent upon the order of the desired controller, the order of the plant and the order of the disturbance model. For example, the plant used has an $N(z)$ of order 1 and a $D(z)$ of order 2. The $P(z)$ model for the ramp input disturbance from Table 1-1 is of order 2. Combining $D(z)$ and $P(z)$ gives order 4. Let the controller have a $B(z)$ of order 3 and an $A(z)$ of order 1 so that the actual controller, which includes the $P(z)$ will have a denominator and

numerator both of order 3. In the Diophantine equation, $D(z)$, $P(z)$ and $A(z)$ combine to form a polynomial of order 5. Therefore, the order of $F(z)$ will be 5 in order to solve Eq. (4). [2]

Functional Description

The high-level block diagram for the overall system, shown in Figure 7, is comprised of three subsystems.

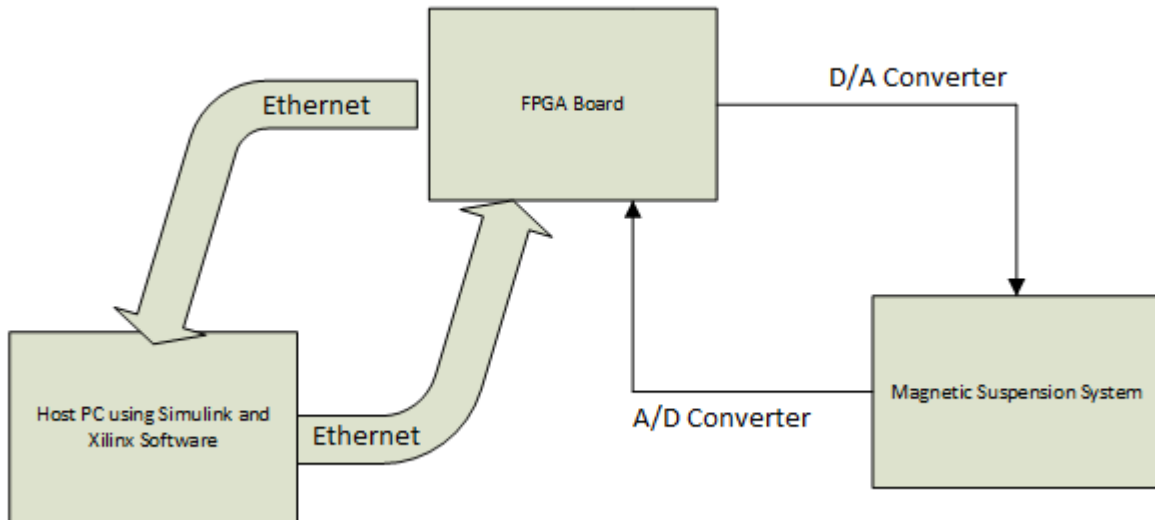

Figure 7 - High-level Functional Diagram

Host PC using Simulink and Xilinx Software

The PC uses Simulink and Xilinx software to compile VHDL code for the Simulink block diagrams and transfer functions. The controller model is then uploaded to the FPGA board using an Ethernet connection.

FPGA Board

The FPGA board holds the mathematical model of the controller model is used to stabilize and control the Magnetic Suspension System. The FPGA board is controlled by the host via Ethernet, which dictates run/stop functionality and also transfer data back to the host. The FPGA board has built in analog to digital and digital to analog converters, which allow data to be sampled from the Magnetic Suspension System as well as allowing control signals to be applied to the system.

Magnetic Suspension System

The magnetic suspension system uses a magnetic force to suspend a hollow metal ball. There are four inputs to the system, a set point, a reference input, a ball position feedback signal, and the disturbance input signal. The set point serves the purpose of giving the system a known location at which the ball should be stabilized. The reference input signal is used when the ball has to track a specific input signal. A sinusoidal reference input waveform, for example, will cause the ball to move in a sinusoidal fashion tracking the input waveform. The third input comes from the photo sensor which converts the ball position to a voltage signal which is fed back to the controller. The fourth input to the system is a disturbance, which will be rejected by the

controller in the FPGA board. The output of the magnetic suspension system is a physical position of the ball.

Figure 8 represents the control block diagram for the system. The inputs and outputs of the system combine to form an error signal, which is composed of the reference, set point, and the position signal. This error signal then enters the FPGA board, which acts as the controller, and generates a correction signal for the plant. The correction signal and the disturbance drive the magnetic suspension system.

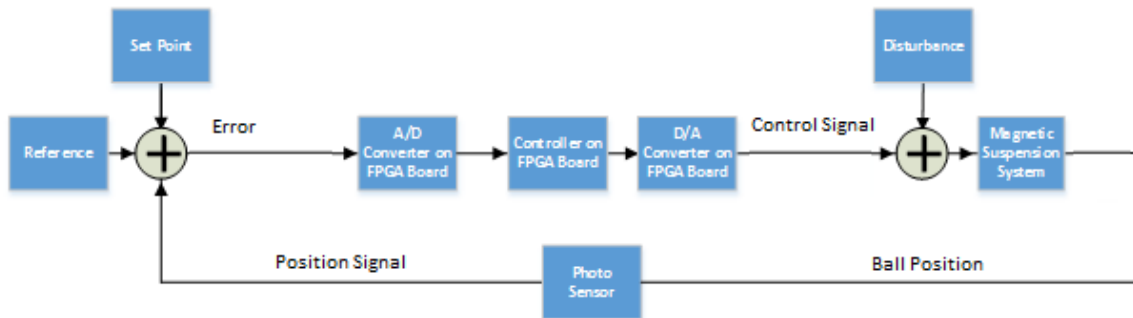

Figure 8 - Control Block Diagram

The magnetic suspension system driver model is shown more clearly in the upper portion of Figure 4. The control signal, “u”, across the Coil Driver Circuit is actually “u” from the controller combine with the disturbance signal, assuming that there is one. The Coil Driver Circuit converts the voltage to a current, which in turn generates a magnetic field around the Electromagnet. This magnetic field is what attracts and ultimately suspends the ball at equilibrium. The current sensor is a one ohm resistor in series with the Electromagnet Coil. Having the current sensor at this location allows experimental data to be taken to verify accuracy. As the ball passes through the photo emitter’s path of radiation, it breaks the light that the photo detector should be seeing. This process is illustrated in the lower portion of Figure 4. This detector converts the broken beam into a voltage representative of the position of the ball.

System Block Diagram

Figure 9 shows the overall system block diagram, which includes the three inputs and the external output. Not shown are the internal signals, which are required to control the system. A further expansion of this system has been shown already in Figure 8.

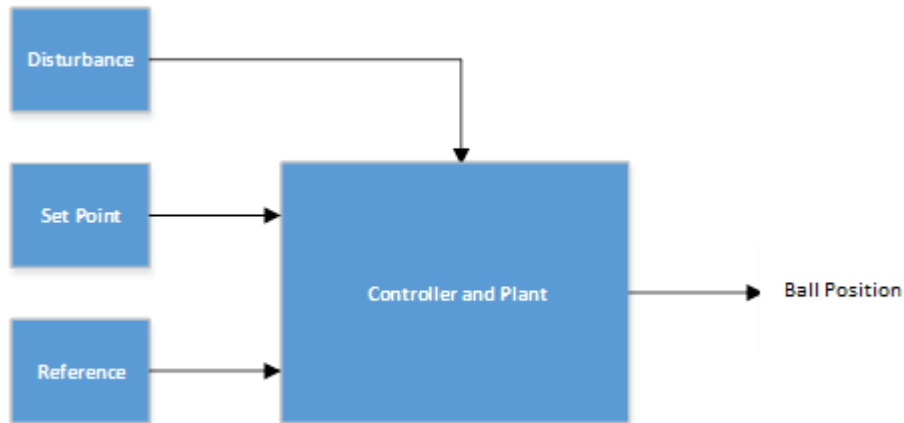

Figure 9 - Overall System Block Diagram

Figure 10 represents the block diagram for the magnetic suspension system. The control signal is summed with the disturbance and this drives the coil driver which converts a voltage to a current. This current induces a magnetic field about the coil, which attracts the ball. The ball then prohibits light from being cast into the photo sensor at a specific level indicative of the location of the ball. This location is converted to the position signal in the form of a voltage.

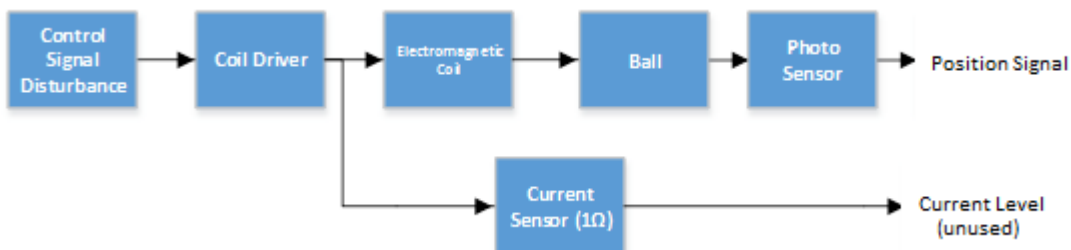

Figure 10 - Block Diagram of Magnetic Suspension System

Figure 11 shows a block diagram of the main components of the system: inputs, feedback signals, A/D converter, control system, D/A converter, plant, photo sensor, and current sensor. The inputs are set point, a point at which the ball should be suspended and the reference signal or a signal which the ball should track about the set point. The feedback signal is position. A/D

converter allows use of a digital controller, the FPGA board. The D/A converter will send the control signal to the plant converting a digital representation to analog voltage. The plant is the Magnetic suspension system.

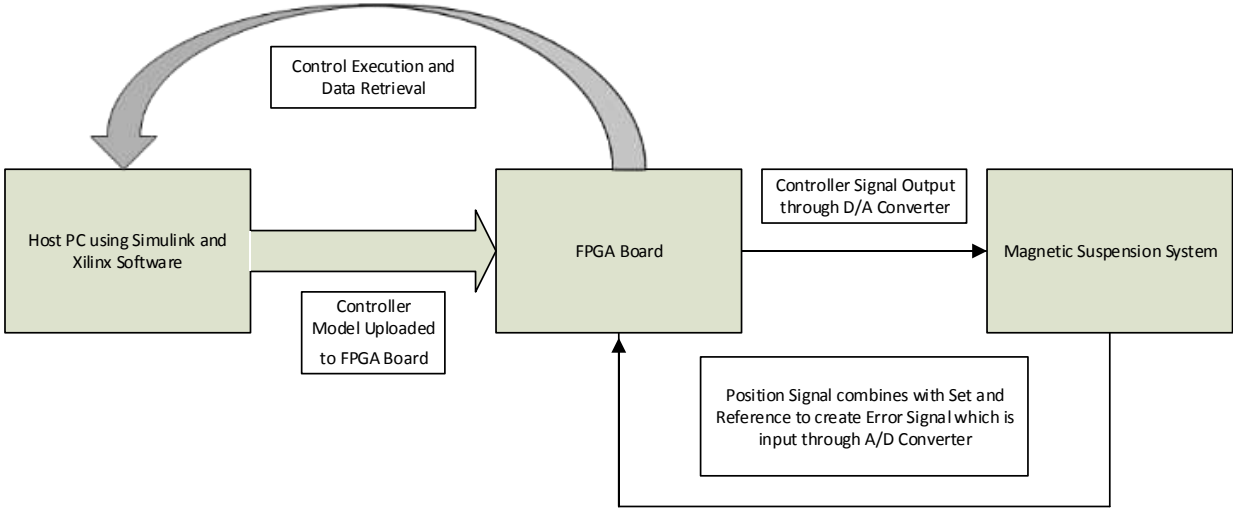

Figure 11 - Controller Block Diagram

Specifications

The specifications of this project were similar to the previous projects that utilized the magnetic suspension system. Using a square wave input with 0.25V amplitude and 0.5Hz frequency, the metal ball shall reach zero steady-state error with approximately 0.41 seconds settling time and 24% overshoot.

The A/D and D/A converters inside the FPGA board will receive the error signal from the plant and send the control signal to the plant. Set point and gain parameters will be user selectable along with a possible disturbance input.

The Xilinx software on the FPGA board will perform all the necessary conversions and calculations to implement the controller. This includes discrete sampling via timers, user input, and output signal to the magnetic suspension plant.

Equipment

- Magnetic Suspension System
- Spartan 3E FPGA board
- Breadboard
- Wires
- Resistors/Capacitors
- Host PC
- Oscilloscope (Tektronix TDS-3012)
- Function Generator (HP E3630A)
- LMC6482 Op-Amps
- +9V Battery and -9V Battery
- LM2940 and LM2990 Voltage Regulators

Schedule

1/22 – 2/25

- Reviewed Internal Model Principle
- Reviewed the magnetic suspension system
- Reviewed previous controllers
- Implemented controllers in Simulink using Xilinx tools
- Tested voltage ranges of previous controllers

2/26

- Midterm Presentation (Capstone Design Project Review)

2/27 – 3/13

- Design, build, and test interface op-amp circuits
- Generate VHDL code and implement on FPGA board
- Demonstrate working magnetic suspension system.

3/14 – 3/24

- Spring Break

3/25 – 4/15

- Prepare presentation and documents.
- First presentation review.

4/16 – 4/17

- Design, build, and test interface circuits using battery.
- Combine system with new circuits using battery and board.
- Demonstrate working magnetic suspension system.
- Print off results
- Take pictures of system and circuits

4/18 – 4/20

- Update lab notebook
- Update website

4/21 – 4/24

- Work on poster and presentation

4/25 – 4/29

- Work on final presentation

References

- [1] Jose A. Lopez and Winfred K.N. Anakwa, "Identification and Control of a Magnetic Suspension System using Simulink and dSPACE Tools", Proceedings of the ASEE Illinois/Indiana 2003 Sectional Conference, March 27, 2004, Peoria, Illinois, U.S.A.
- [2] Jon Dunlap, "Design of Disturbance Rejection Controllers for a Magnetic Suspension System", Bradley University, IEEE Department, May 8, 2006, Peoria, Illinois, U.S.A.
- [3] Gary Boline and Andrew Michalets, "Magnetic Suspension System Control Using Position and Current Feedback", Bradley University Department of Electrical and Computer Engineering, May 17, 2007, Peoria, Illinois, U.S.A
- [4] B.A. Francis and W.M. Wonham, "The Internal Model Principle of Control Theory," *Automatica*. Vol. 12, pp 457-465, 1976.