

Altera UP2 Expansion Board (AEB)

System Block Diagram

by

Jeremy Seith & Matthew McCoy

Advisor: Mr. Gutschlag
Senior Capstone Project
11/22/05

Introduction

The goal of this project is to build an Altera UP2 Education Kit expansion board (AEB) that will make it a more useful test bench for complex designs. The AEB will be designed and packaged for use in university laboratories. Certain features added on the AEB will use a toggle switch or jumper to enable or disable it from the original UP2 development kit. The toggle switches will allow the use of I/O pins on the FLEX and MAX PLD's with specific features only when needed. The overall system block diagram is shown in Figure 1. The PCB layout is shown in Figure 2.

Figure 1
Altera Expansion Board SystemBlock Diagram

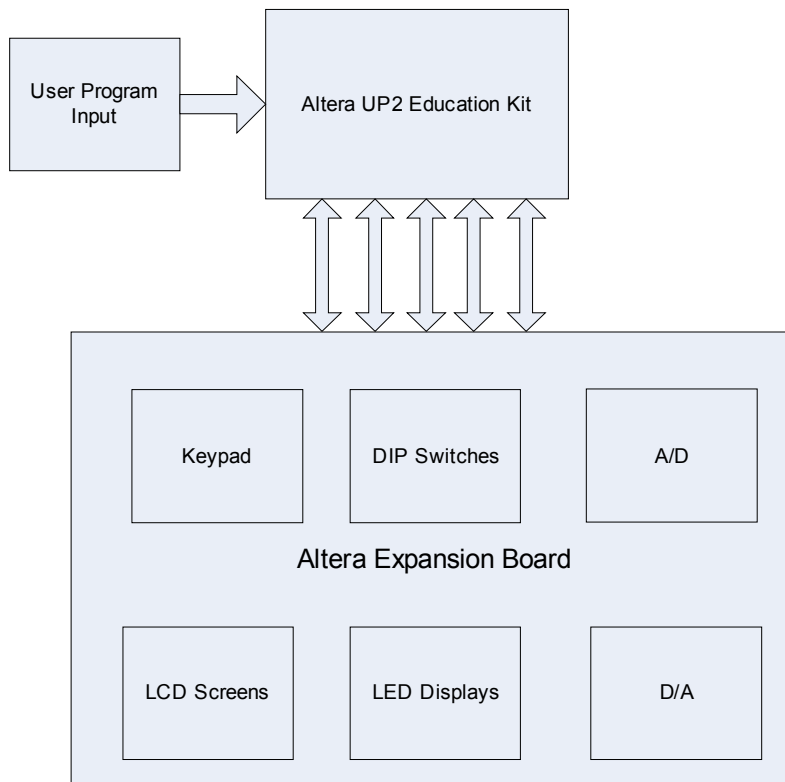
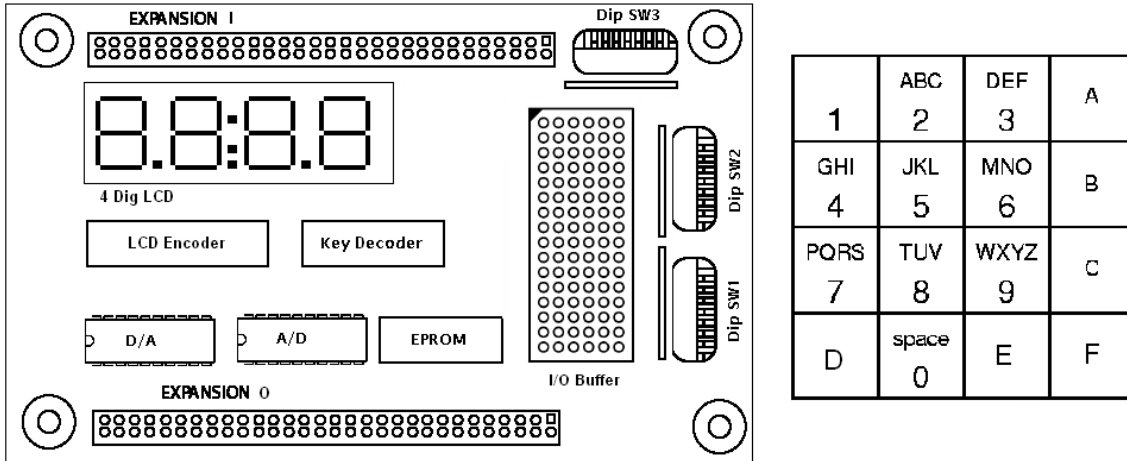

Figure 2
Altera Expansion Board PCB Layout



Altera UP2 Education Kit

The Altera University Program UP2 Kit is designed to help universities teach digital logic design. The package provides an Altera MAX7128S Programmable Logic Device (MAX) and an Altera FLEX 10K70 PLD (FLEX) interfaced with a pair of dual 7-segment displays, 16 LED's, three DIP switches, and 4 push-buttons. The UP2 kit will be the base of which the AEB expands upon.

A/D and D/A converters

The A/D and D/A converters will allow for the Altera chips to sample and output analog signals. This feature will make it possible for the user to test more complex designs than with the UP2 kit alone.

Keypad

The keypad will be a common alphanumeric keypad with numbers 0 through 9 and letters A through F. This will make it easier for the user to test and debug programs that use alpha-numeric inputs.

Displays

A 4 line character LCD display and a 4-digit LCD display will be added to the expansion board. The 4-digit display will be an onboard device while the LCD screen will be mounted off of the board to save space.

Dip Switches

The DIP switches will allow inputs to be set that are meant to be set and held. This will be just an added convenience for the user.