

Project Progress Report

Implementation of Conventional and Neural Controllers Using Position and Velocity Feedback

Week Ending: February 6, 2000

By:

Chris Spevacek and Manfred Meissner

Advisor:

Dr. Gary Dempsey

Signature: _____

Grade: _____

Objective

The objective for the week was to finish the system identification of the robot arm system with a small arm.

Progress

System Identification:

We assumed that the robot arm system is a three-pole system in the form of

$$Gp = \frac{ke^{-std}}{s(s+p1)(s+p2)} \quad (1)$$

The pole-zero description neglecting time delay for this system is shown in Fig. 1.

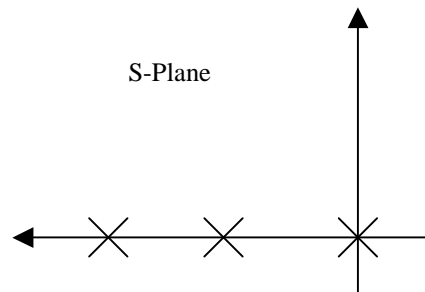

Fig. 1 Pole-Zero Map Of Plant

The first pole was found at the origin. To find the first pole we used WinCom to simulate an open loop control system which is shown in Fig. 2.

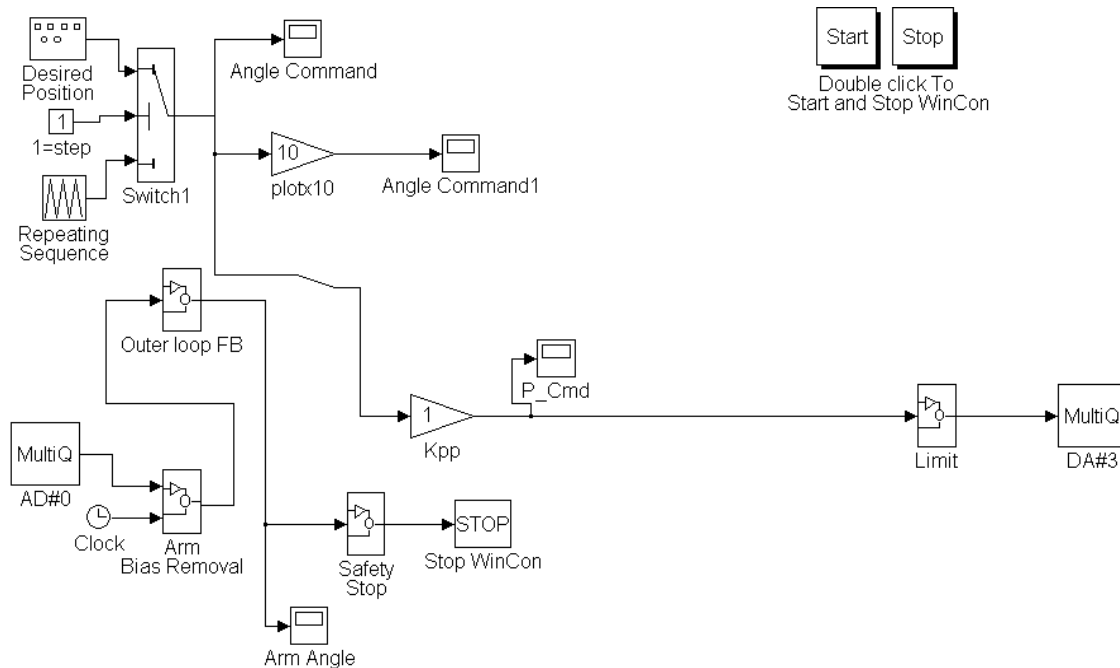

Fig. 2. Open Loop Block Diagram

Time Delay:

The next thing to do was find the time delay. To find time delay we measured the distance between the falling edge of the input signal and output signal, this is shown in Fig. 3. This also illustrates the integrator action due to the pole at the origin.

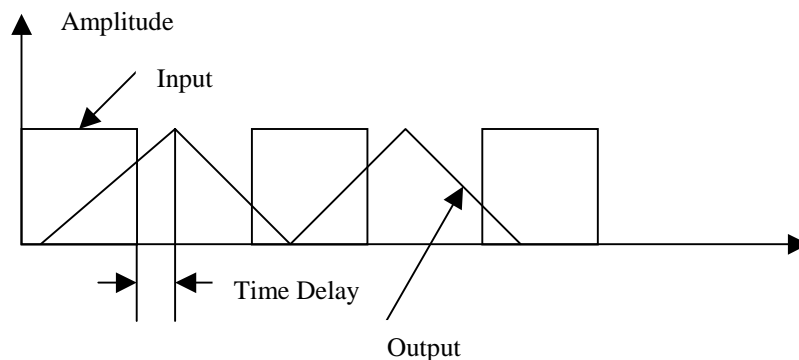

Fig. 3. Time Delay Measurement

The input signal was a square wave and the output was a ramp wave. The time delay in the counter clockwise direction was found to be about 25ms and in the clockwise direction was found to be 15ms. The reason for the difference in time delay is that the friction of the potentiometer is greater in the counter clockwise direction. Since we are designing for worst case we are using the 25ms time delay.

Second Pole:

The method used to find the second pole was to observe the phase angle of the plant at 135° . An angle of 135° was chosen because that should be half way between the

second and third pole. The method used to find the phase angle is to measure the degrees between the peaks of the input and output waves as shown in Fig. 4.

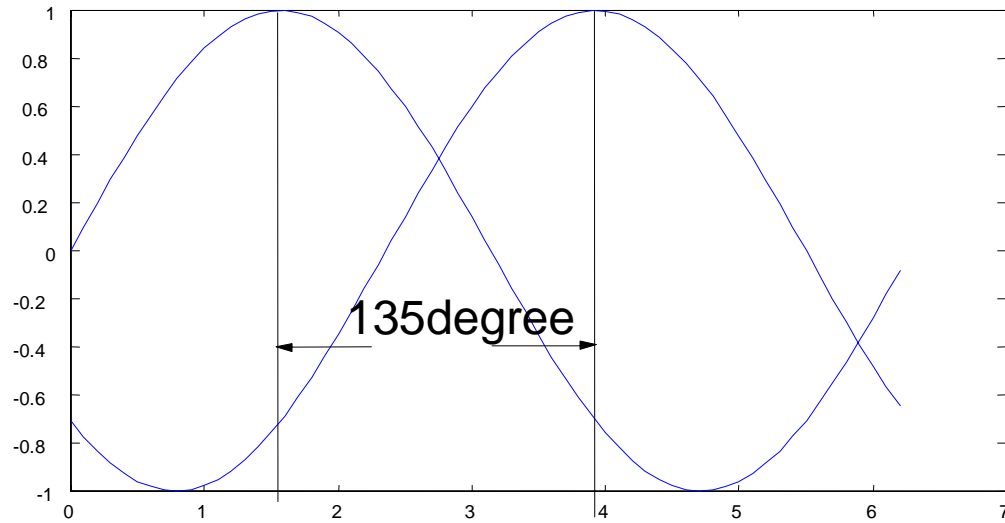

Fig. 4. Phase Angle Measurement

When the phase angle equaled 135° , the frequency was recorded to determine the second pole by using

$$PhaseAngle = -90 - \tan^{-1} \frac{\omega}{p} - Td\omega(57.3) \quad (2)$$

We found that at 5Hz the phase angle was the desired value. Using (2) we found that the time delay was the dominant factor. So we tried other frequencies and came to the same result. This told us that the second pole would only have a minor impact on the system. Since the second pole was unable to be found it would not be possible to find the third pole. The general form of the transfer function we found is

$$Gp = \frac{K e^{std}}{s} \quad (3)$$

Next thing that had to be found was the gain k of the plant. To do this we chose to find the gain at 1rad/sec. For a first order system with a pole at the origin the gain is where the bode plot crosses the 1rad/sec line. The input magnitude was 2.61 volts and the output magnitude was 1.57. Using the formula shown in (4) we found the gain to be 0.6051.

$$K = \frac{Vout}{Vin} \quad (4)$$

We then designed a proportional controller to test the model. The block diagram is shown in Fig. 5.

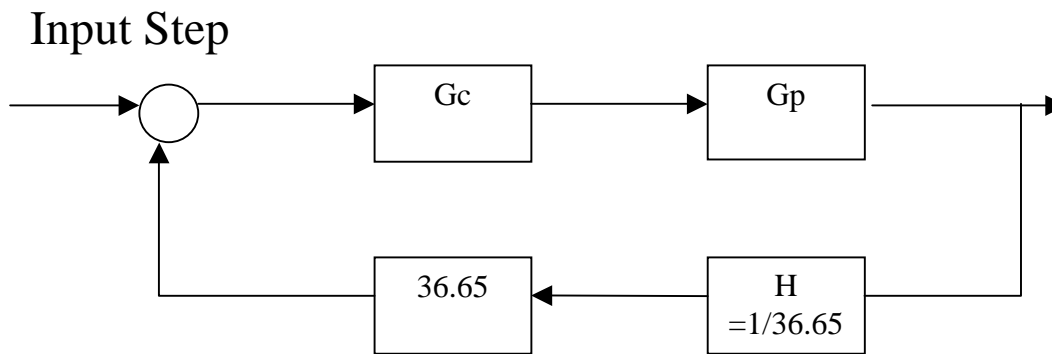

Fig 5. Block Diagram

The controller was designed for a phase margin of 60° , with this we found the crossover frequency to be about 21rad/sec by using (2). Open loop design was used to find the proportional controller because the magnitude will be equal to one as shown in (5).

$$1 = |Gc(j\omega)Gp(j\omega)H * 36.63| \quad (5)$$

Time delay does not have an affect on magnitude so that can be ignored. The first time the controller was designed we found that k should be about 36. This was then simulated with the robot arm using a closed loop block diagram shown in Fig. 6.

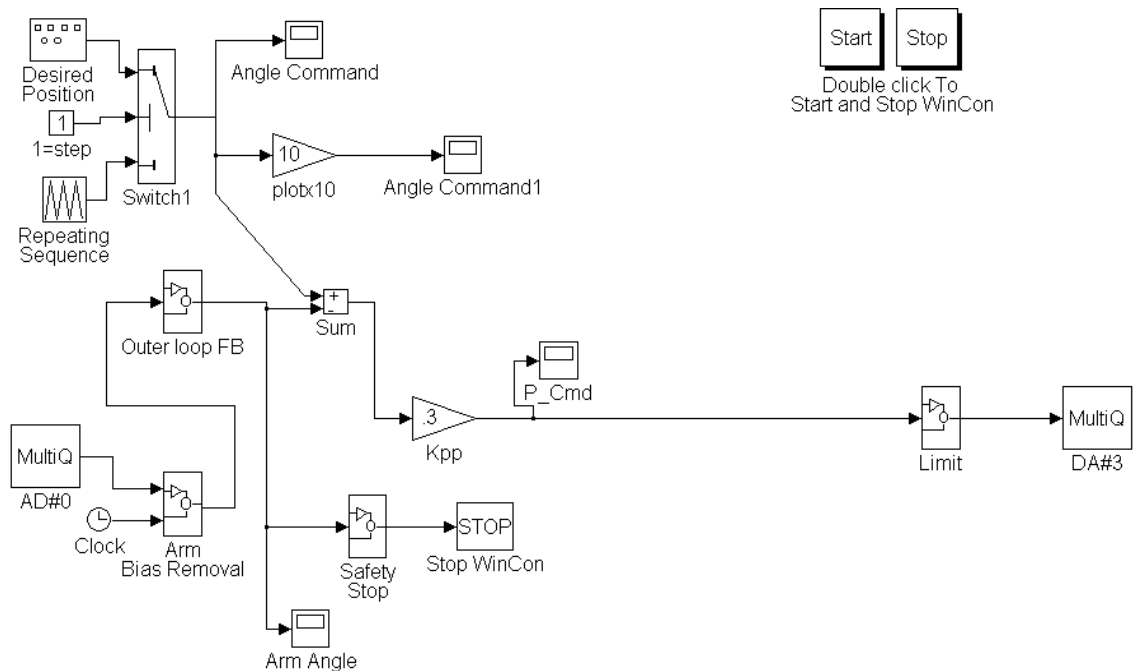

Fig. 6. Closed Loop Block Diagram

When ran with k equal to 36 for the controller, the plant was found to be unstable. So we designed it again remembering this time that the potentiometer had a gain associated with it of 1/36.5 so we found the gain of the plant to be 21.5. With this new gain for the plant

we redesigned the controller and found that the gain k was equal to 0.967. The MatLab results are shown in Fig. 7. The controller still has to be tested.

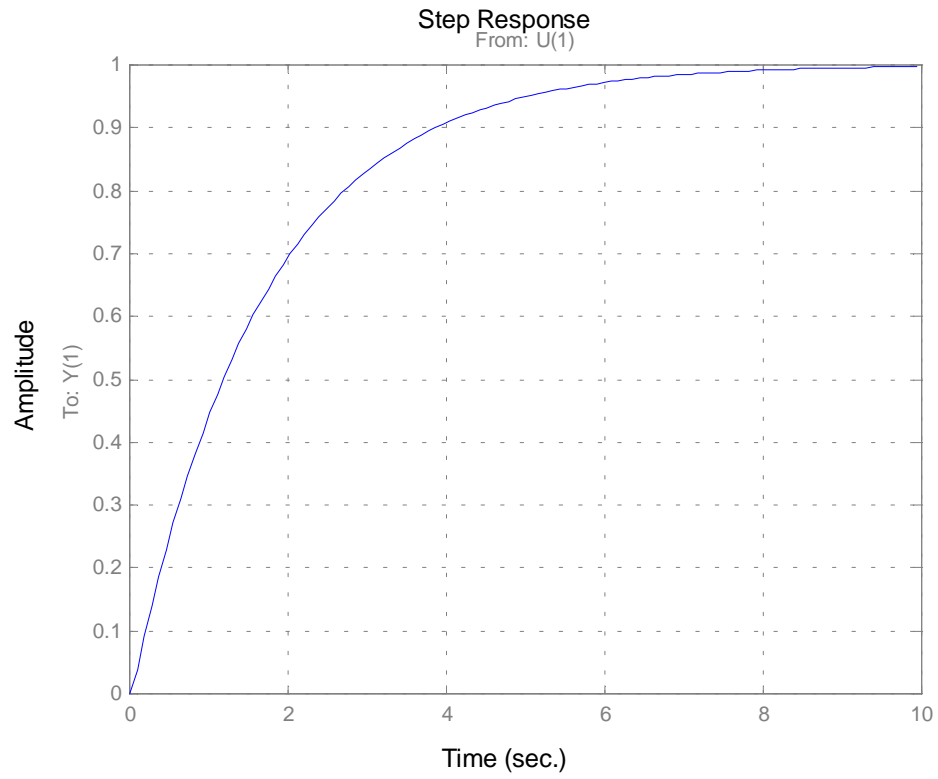

Fig. 7. MatLab Simulation of Controller